



Automotive  
Division  
The Global Voice of Quality™



# Failure Mode and Effects Analysis based on *FMEA 4<sup>th</sup> Edition*

Mark A. Morris  
ASQ Automotive Division Webinar

November 30, 2011



[mark@MandMconsulting.com](mailto:mark@MandMconsulting.com)  
[www.MandMconsulting.com](http://www.MandMconsulting.com)

# *Purpose* of this Course

---

- Enable participants to understand the importance of FMEA in achieving robust capable designs and processes.
- Teach participants how to improve the efficiency and effectiveness of their FMEA efforts.
- Get the right people involved in the process of FMEA, and get results.
- Have Fun Learning!!!

# Learning Objectives

Participants will be able to:

- ✓ Explain the purpose, benefits and objectives of FMEA.
- ✓ Select cross-functional teams to develop FMEAs.
- ✓ Develop and complete a FMEA.
- ✓ Review, critique, and update existing FMEAs.
- ✓ Manage FMEA follow-up and verification activities.
- ✓ Develop FMEAs in alignment with AIAG FMEA reference manuals.

# *Changes* in the FMEA Manual (4<sup>th</sup> Ed.)

- Improved format, easier to read.
- Better examples to improve utility.
- Reinforces need for management support.
- Strengthens linkage between DFMEA/PFMEA.
- Ranking tables better reflect real world use.
- Introduces alternative methods in use.
- Suggests better means than RPN to assess risk.
- Recommends against threshold RPN values to initiate required action.

# Process FMEA Report

**POTENTIAL  
FAILURE MODE AND EFFECTS ANALYSIS  
(Process FMEA)**

FMEA Number \_\_\_\_\_

Page \_\_\_\_ of \_\_\_\_

Item \_\_\_\_\_

Process Responsibility \_\_\_\_\_

Prepared by \_\_\_\_\_

Model Year(s) Program(s) \_\_\_\_\_

Key Date \_\_\_\_\_

FMEA Date (Orig.) \_\_\_\_\_ (Rev.) \_\_\_\_\_

Core Team \_\_\_\_\_

Process Step Function	Potential Failure Mode	Potential Effects of Failure	S e v	C l a s s	Potential Causes/ Mechanisms of Failure	O c c	Current Process Control (Prevention)	Current Process Control (Detection)	D e t	R. P. N.	Recommended Actions	Responsibility & Target Completion Date	Action Results						
													Actions Taken	S e v	O c c	D e t	R. P. N.		



# Process FMEA Analysis

Process Step Function	Potential Failure Mode	Potential Effects of Failure	Sev	Class	Potential Causes/ Mechanisms of Failure	OCC	Current Process Control (Prevention)	Current Process Control (Detection)	Det	R. P. N.

Process Step is simply the focus of the analysis

Describe how the item could **potentially fail** to perform its function

Identify potential **causes** of the item not performing its intended function

This column is used to document methods that have been used to **detect** either the cause or the failure mode

Describe the **function** or requirement to be analyzed

State the **effects** of the failure in terms of the specific system, subsystem, or component being analyzed

This column is reserved for the methods that have been used to **prevent** a specific cause

# Process FMEA Analysis

Process Step Function	Potential Failure Mode	Potential Effects of Failure	Severity	Classification	Potential Causes/ Mechanisms of Failure	Occurrence	Current Process Control (Prevention)	Current Process Control (Detection)	Detection	R. P. N.
			<p><b>Severity</b> evaluates the impact of the effect.</p>	<p><b>Classification</b> is an optional column commonly used to identify safety risks.</p>		<p><b>Occurrence</b> rates how often a specific cause is likely to result in the failure mode being analyzed.</p>		<p><b>Detection</b> ranks our ability to detect either a cause or a resulting failure mode. Use best detection available.</p>		<p><b>Risk Priority Number</b> is the product of the severity, occurrence, and detection rankings.</p>

# Four Common Classes of FMEA

- **System FMEA**
  - Focuses on how interactions among systems might fail.
- **Design FMEA**
  - Focuses on how product design might fail.
- **Process FMEA**
  - Focuses on how processes that make the product might fail.
- **Machinery FMEA**
  - Focuses on how machinery that perform processes might fail.

The focus for this evening is on Process FMEA.





# AIAG Model for Quality Planning

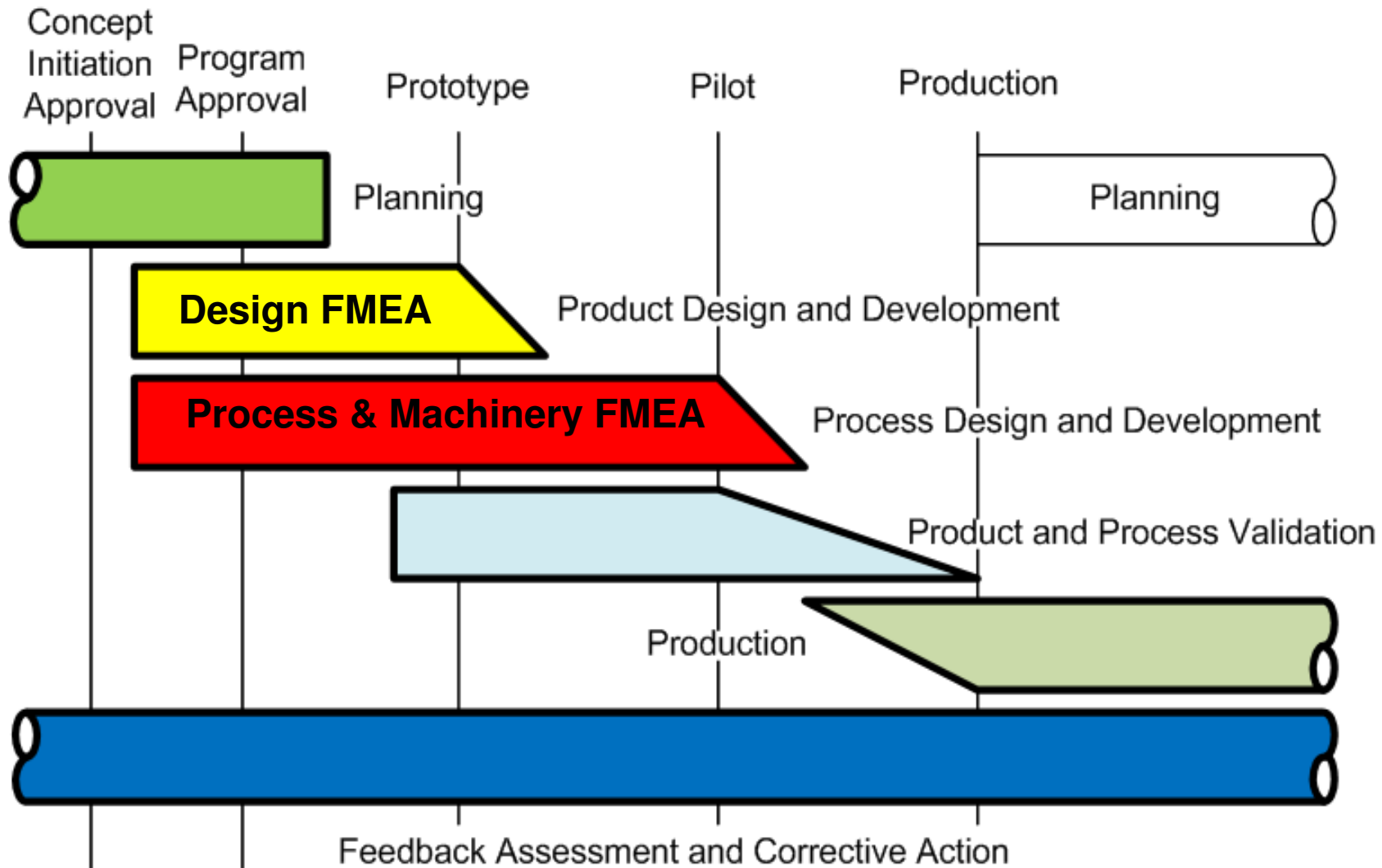

# Understanding a *Failure Sequence*

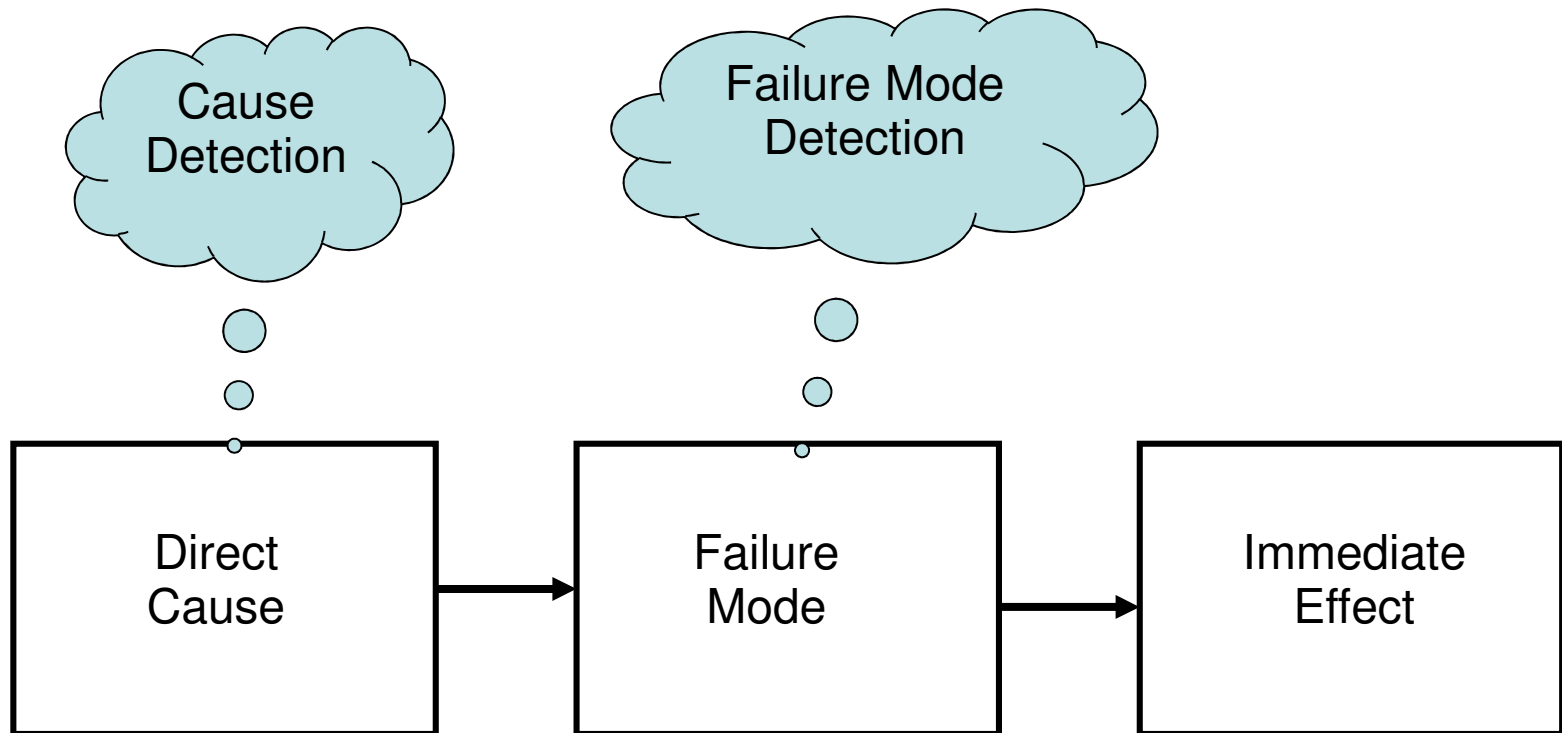

# Is it a *Cause* or *Failure Mode*?

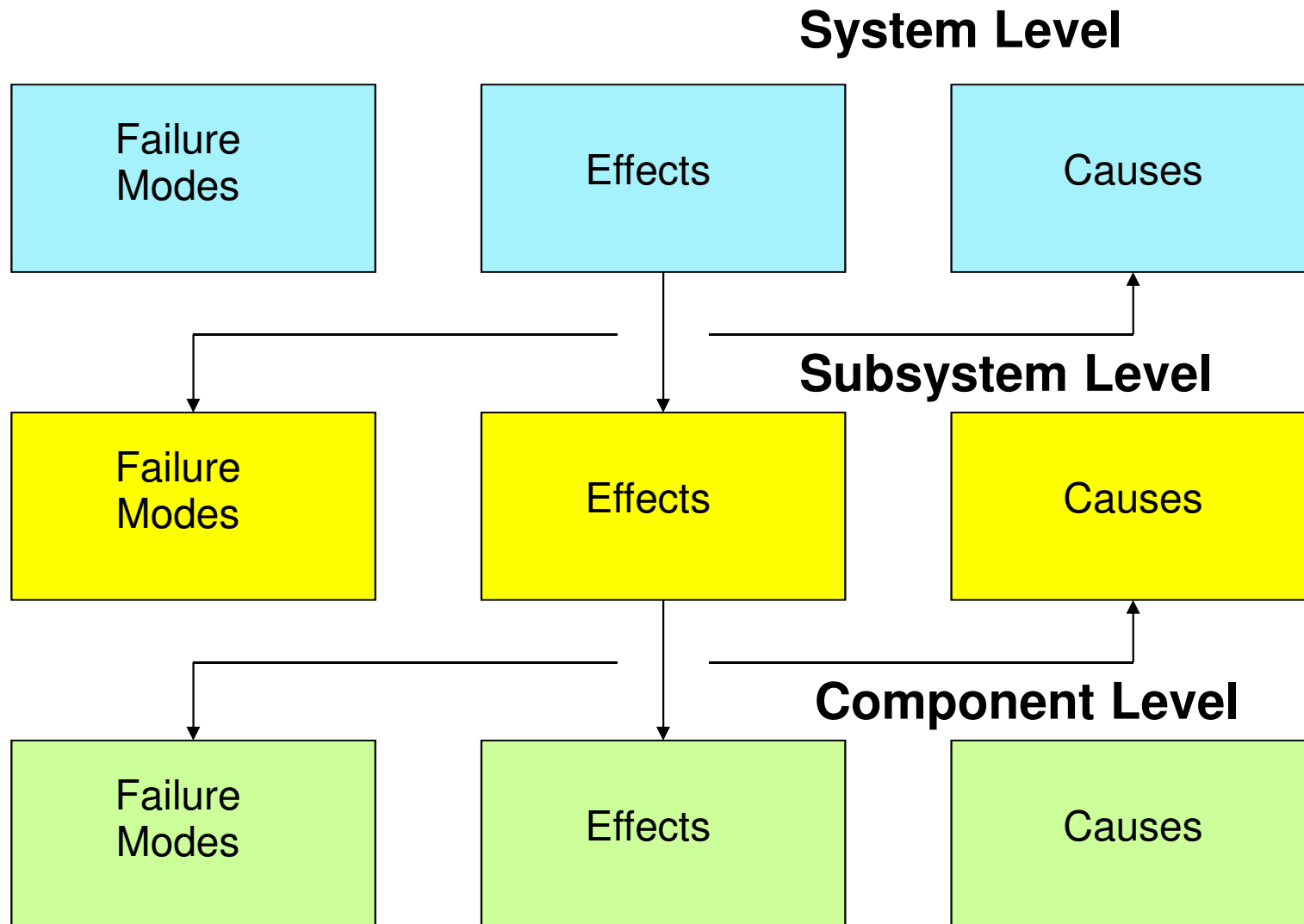

# Examples of Weld Process Failure Modes

- **System** (Welding Line)
  - Robot Failure
  - Loss of Incoming Water
  - No Signal to Weld
- **Subsystem** (Weld Gun)
  - Cracked Jaw
  - Failed Servo Motor
  - Failed Shunt
- **Component** (Servo Motor)
  - Overheats
  - Loss of Position
  - Premature Seal Failure

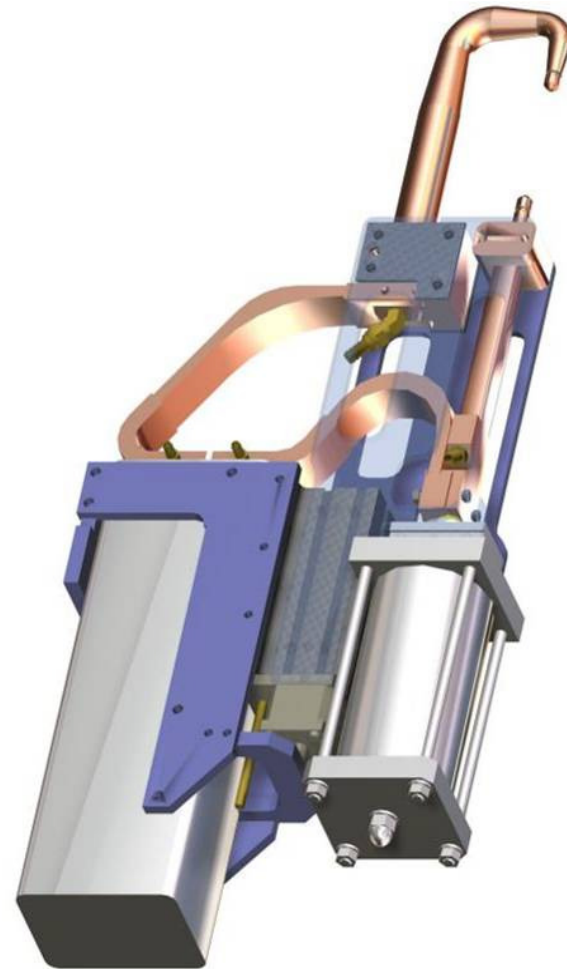

# A Rational Structure for Quality Planning <sup>TM</sup>

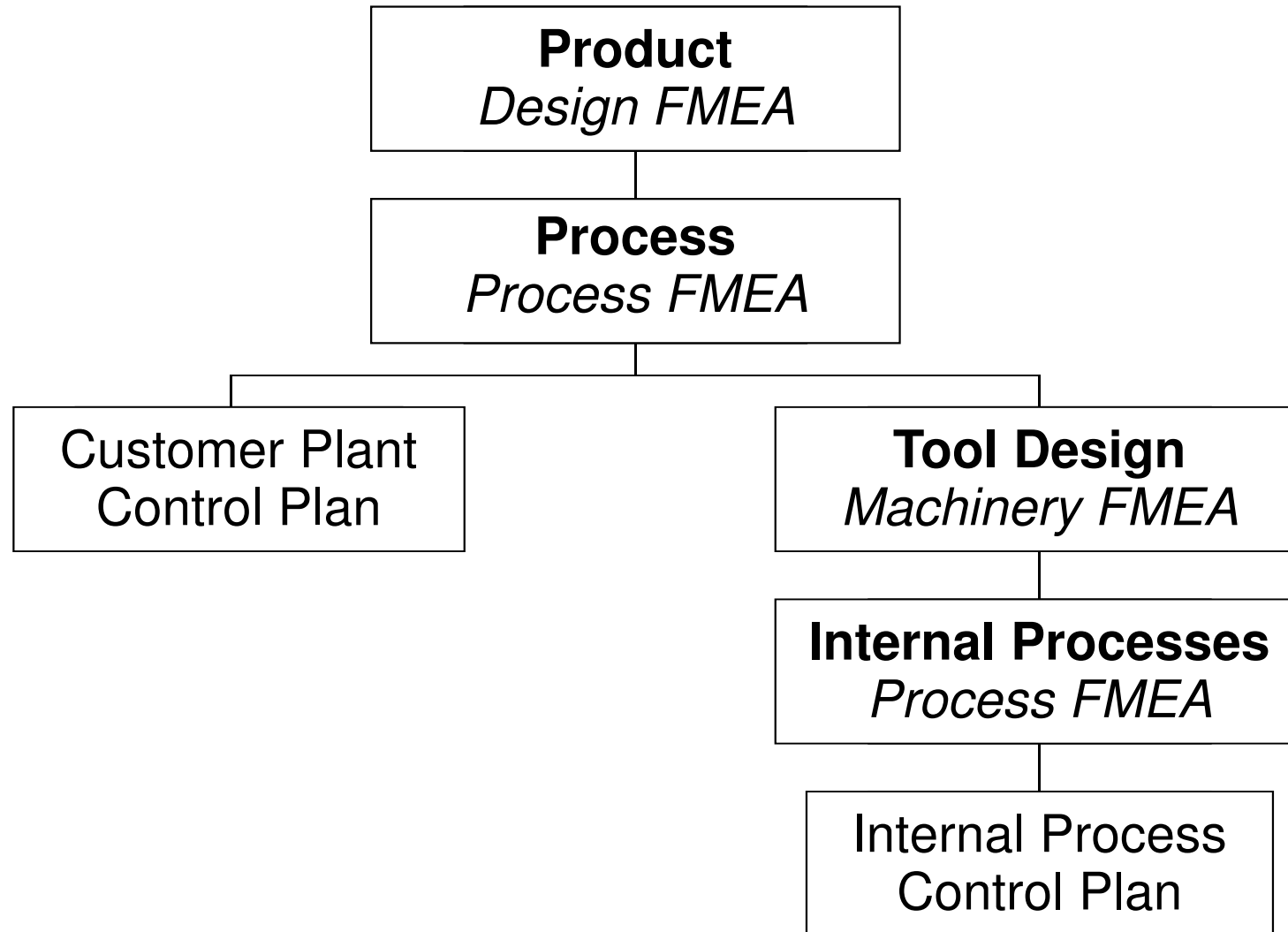

# Motivation for Specific FMEAs

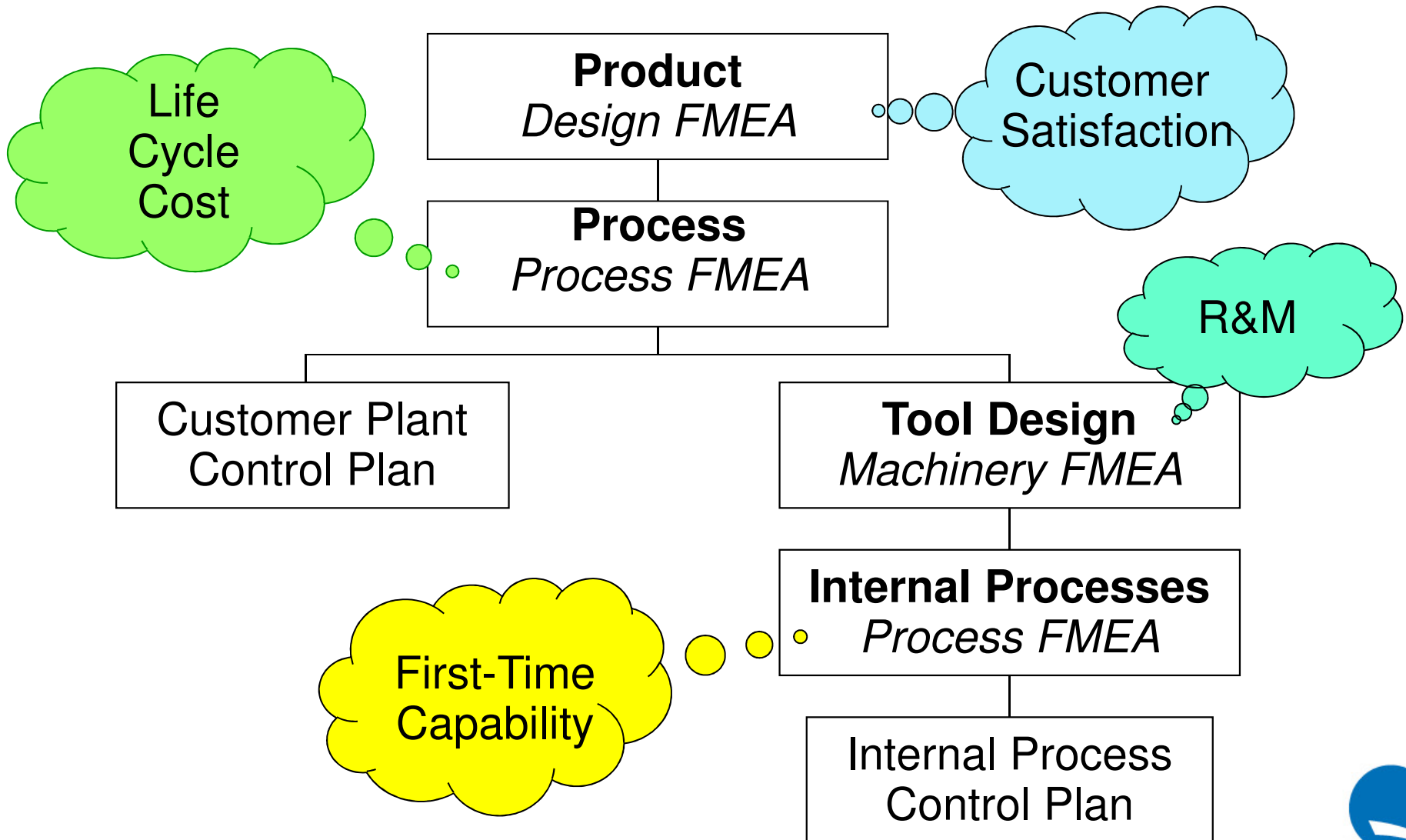

# DFMEA *Information Linkages*

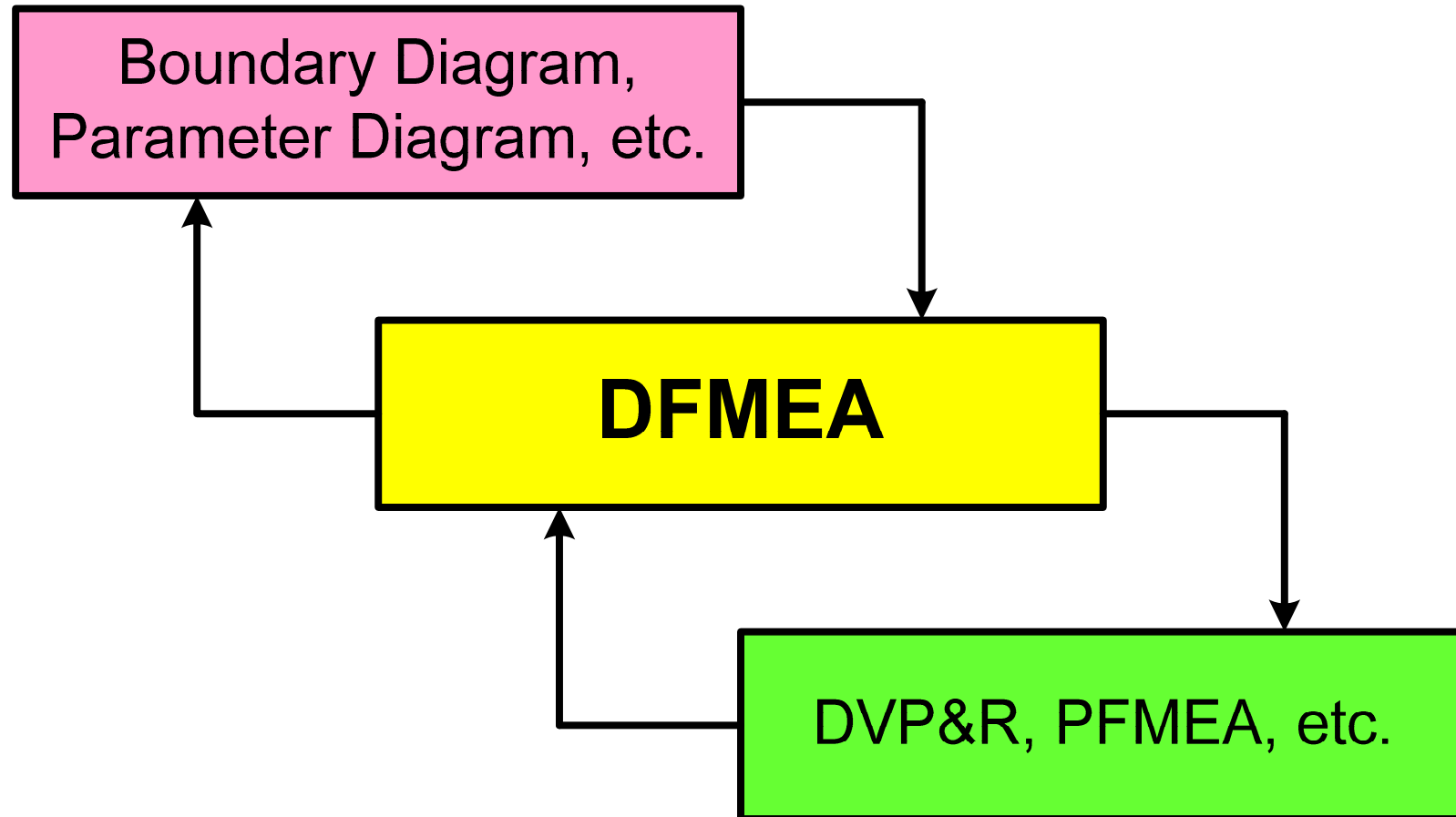

# The Underlying Message

---

- Don't correct a weak product design by focusing on a super robust process.
- Don't correct a weak process design by focusing on design changes to the product.



# PFMEA *Information Linkages*

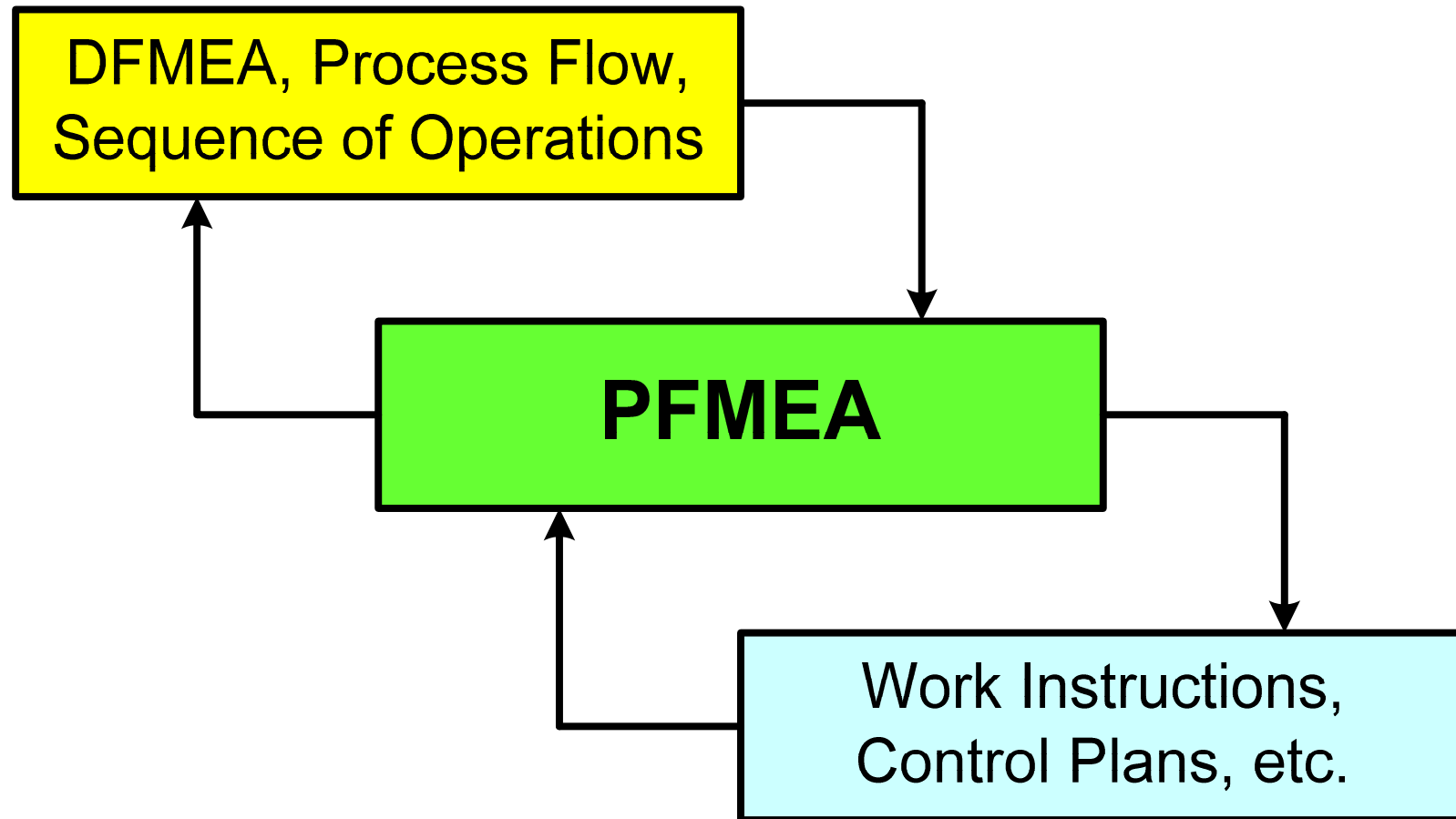

# Rational Structure and Project Specific Control Plans

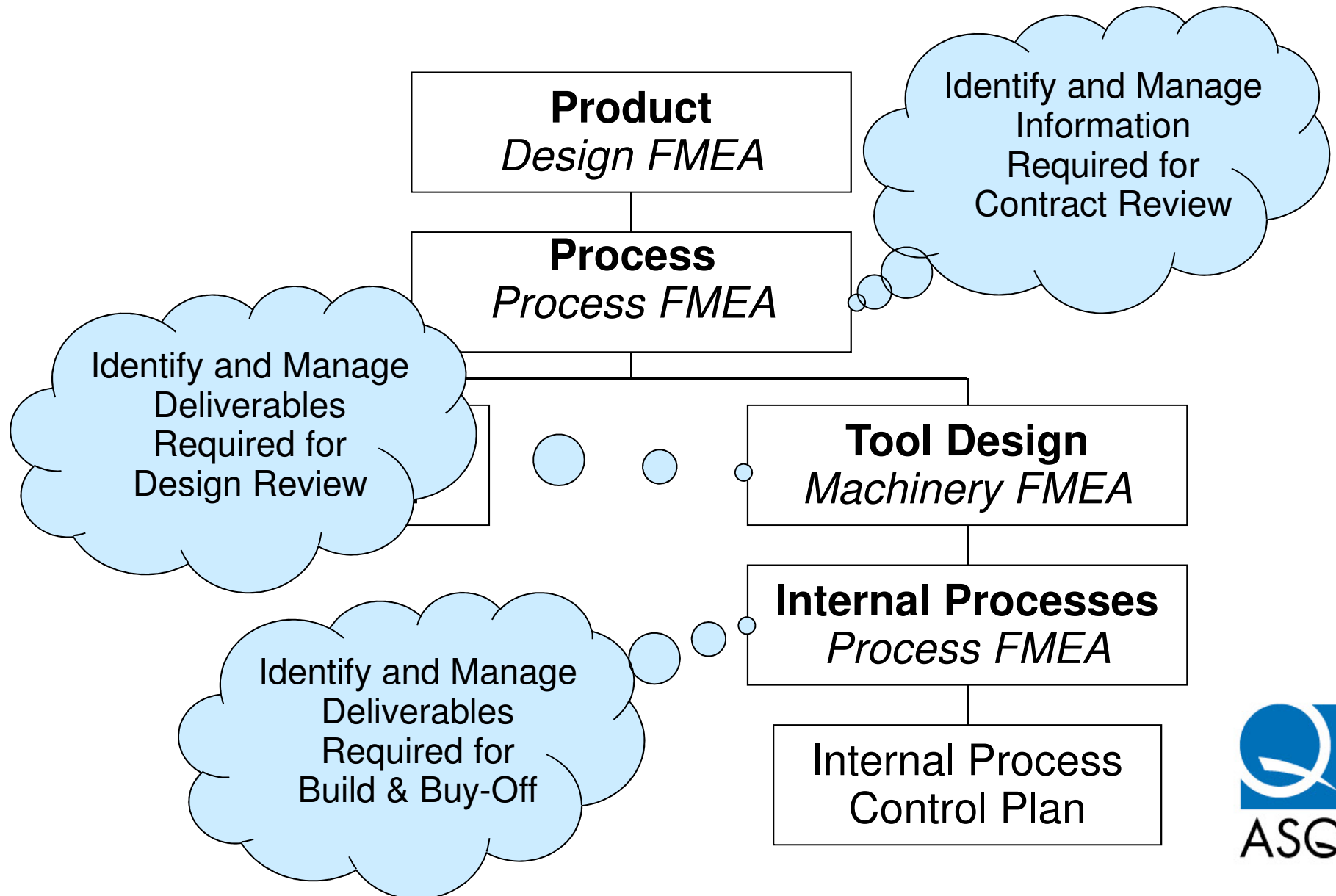

# Three Phases of Control Plan

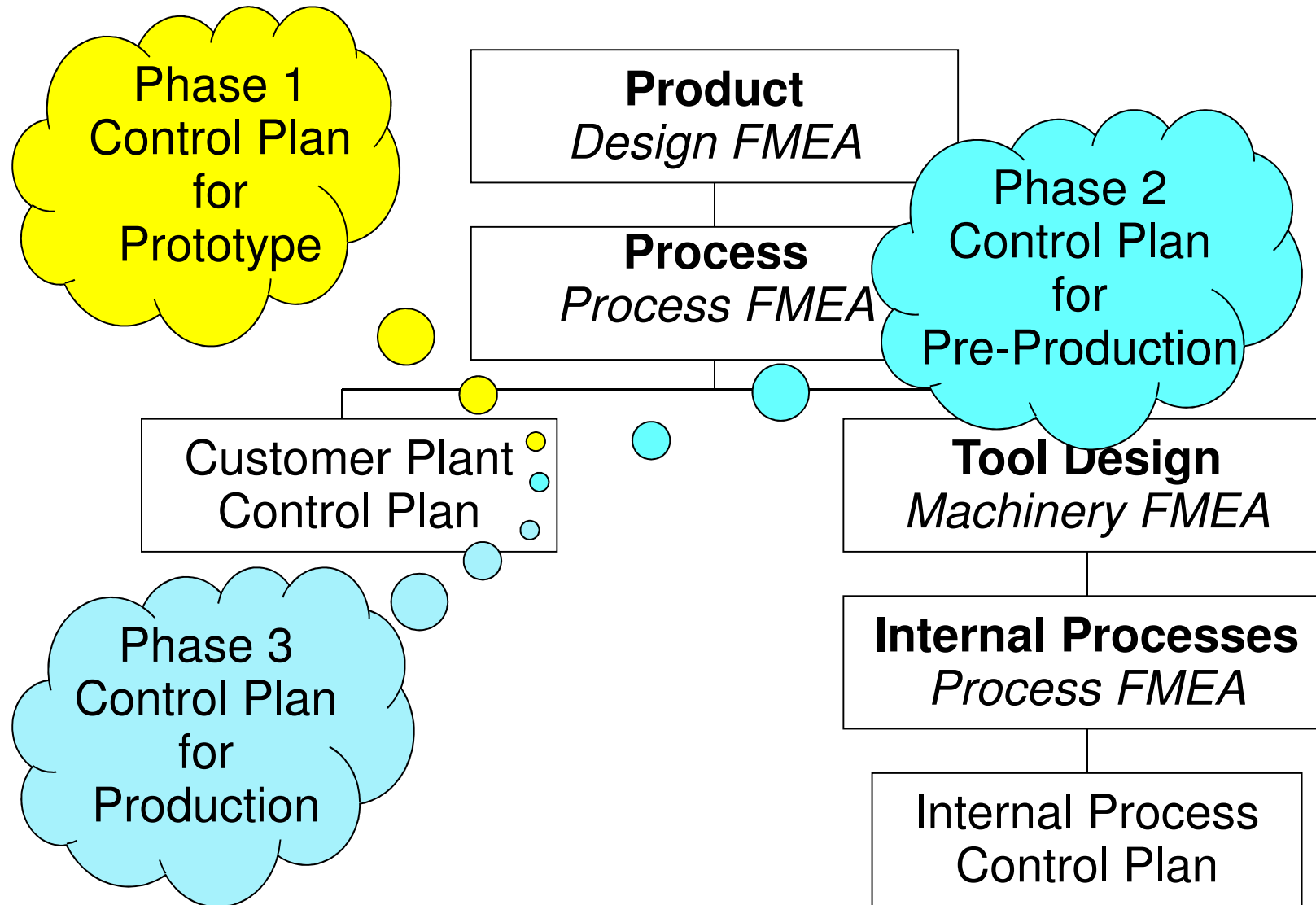

# Containment Considerations

---

- Cost of Defects
- Risk of Defects
- Bracketing Strategies
- Protecting On-Time Delivery
- Cost of Stopping Production
- Cost of Recall Campaigns
- Benefits of Traceability

# FMEA *Teams*

- Multi-functional teams are essential.
- Ensure expertise from manufacturing engineering, plant operations, maintenance, and other appropriate sources.
- Select team with ability to contribute:
  - Knowledge
  - Information
  - Experience
  - Equity
  - Empowerment
- Pick the right team members, but limit the number of team members based on the scope of the issues being addressed.
- In addition to the FMEA team.
  - Call in Experts as Needed

# Relevant Resources and Expertise

	Customer	Program Management	Integration Responsible Individuals	Service Operations and Warranty	Safety	Manufacturing and Assembly	Materials, Packaging, and Logistics	Engineering and Statistical Analysis	Quality and Reliability	Equipment Manufacturer	Plant Maintenance
Scope											
Functions, Requirements, Expectations											
Potential Failure Mode – how the process might fail											
Effects or Consequences of the Failure											
Causes of the Failure											
Current Controls - Prevention											
Current Controls - Detection											
Severity, Occurrence, Detection, RPN											
Recommended Actions Required											

# Common *Team Problems*

- No Common Understanding of FMEA
- Overbearing Participants
- Reluctant Participants
- Opinions Treated as Facts
- Rush to Accomplishments
- Digression and Tangents
- Hidden Agendas
- Going through the Motions
- Seeing FMEA as a Deliverable



# A *Process Flow* for FMEA

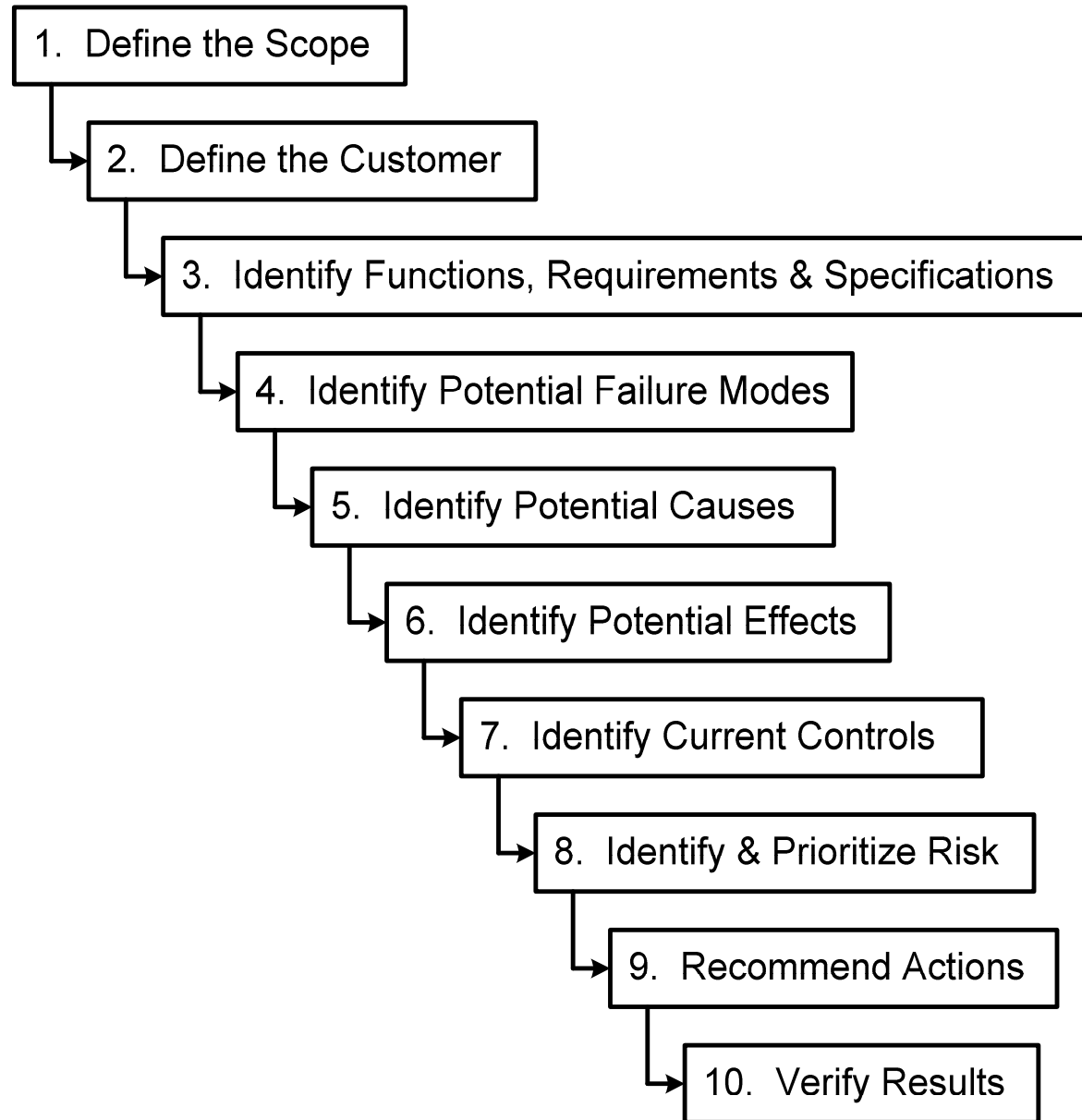



# 1. Define the Scope

---

- Scope is essential because it sets limits on a given FMEA, that is, it makes it finite.
- Several documents may assist the team in determining the scope of a Process FMEA:
  - Process Flow Diagram
  - Relationship Matrix
  - Drawings, Sketches, or Schematics
  - Bill of Materials (BOM)

# Process Flow Charts

High Level Flow Chart

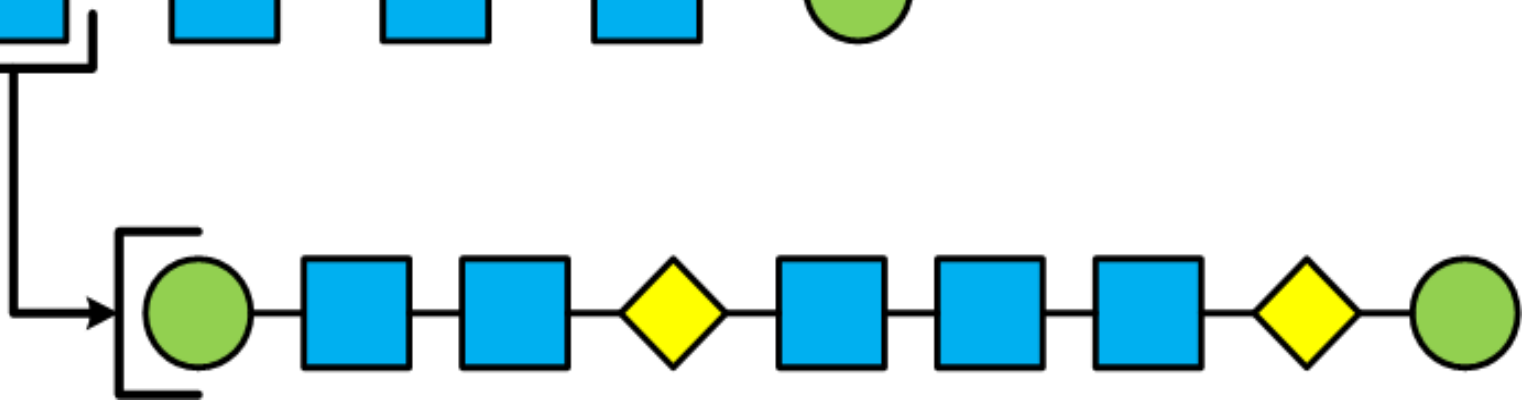
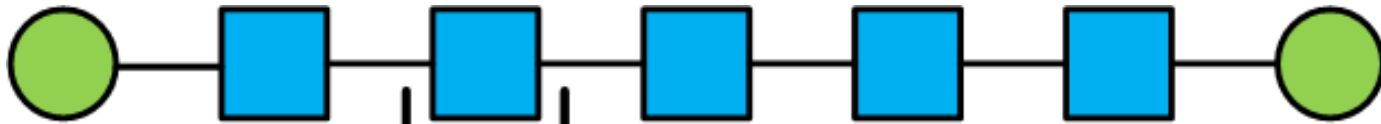

Detailed Flow Chart

## 2. Define the Customer

---

- Four major customers need to be considered:
  - End Users
  - OEM Plants
  - Supplier Plants
  - Government Agencies (safety and environment)
- Customer knowledge can contribute precise definition of functions, requirements, and specifications.

### 3. Identify Functions, Requirements, Specifications

---

- Identify and understand the process steps and their functions, requirements, and specifications that are within the scope of the analysis.
- The goal in this phase is to clarify the design intent or purpose of the process.
- This step, well done, leads quite naturally to the identification of potential failure modes.

# Defining *Functions*

- Describe the Functions in Concise Terms
- Use “Verb-Noun” Phrases
- Select Active Verbs
- Use Terms that can be Measured
- Examples:
  - Pick and Place Unit      Secure Part
  - Advance Part
  - Locate Part
  
  - Robot                              Position Weld Gun

# ***Process Steps, Functions, Requirements***

***Process Steps***

***Functions***

***Requirements***

<i><b>Process Steps</b></i>	<i><b>Functions</b></i>	<i><b>Requirements</b></i>

# Process and Functional Requirements

Process Steps	Functions	Requirements
CLEARANCE HOLE FOR 12MM BOLT	DRILL HOLE THRU	HOLE SIZE $\phi 12.5 \pm 0.25$
		LOCATION $\phi \phi 0.5 @ MMC$
		REMOVE ALL BURRS

# Identify Process and Function – Traditional Format

Process Step Function	Potential Failure Mode	Potential Effects of Failure	S e v	C l a s s	Potential Causes/ Mechanisms of Failure	O c c	Current Process Control (Prevention)	Current Process Control (Detection)	D e t	R. P. N.
Clearance hole for 12 mm bolt  - Hole size  - Hole location  - Free of burrs										



# Identification of *Failure Modes*

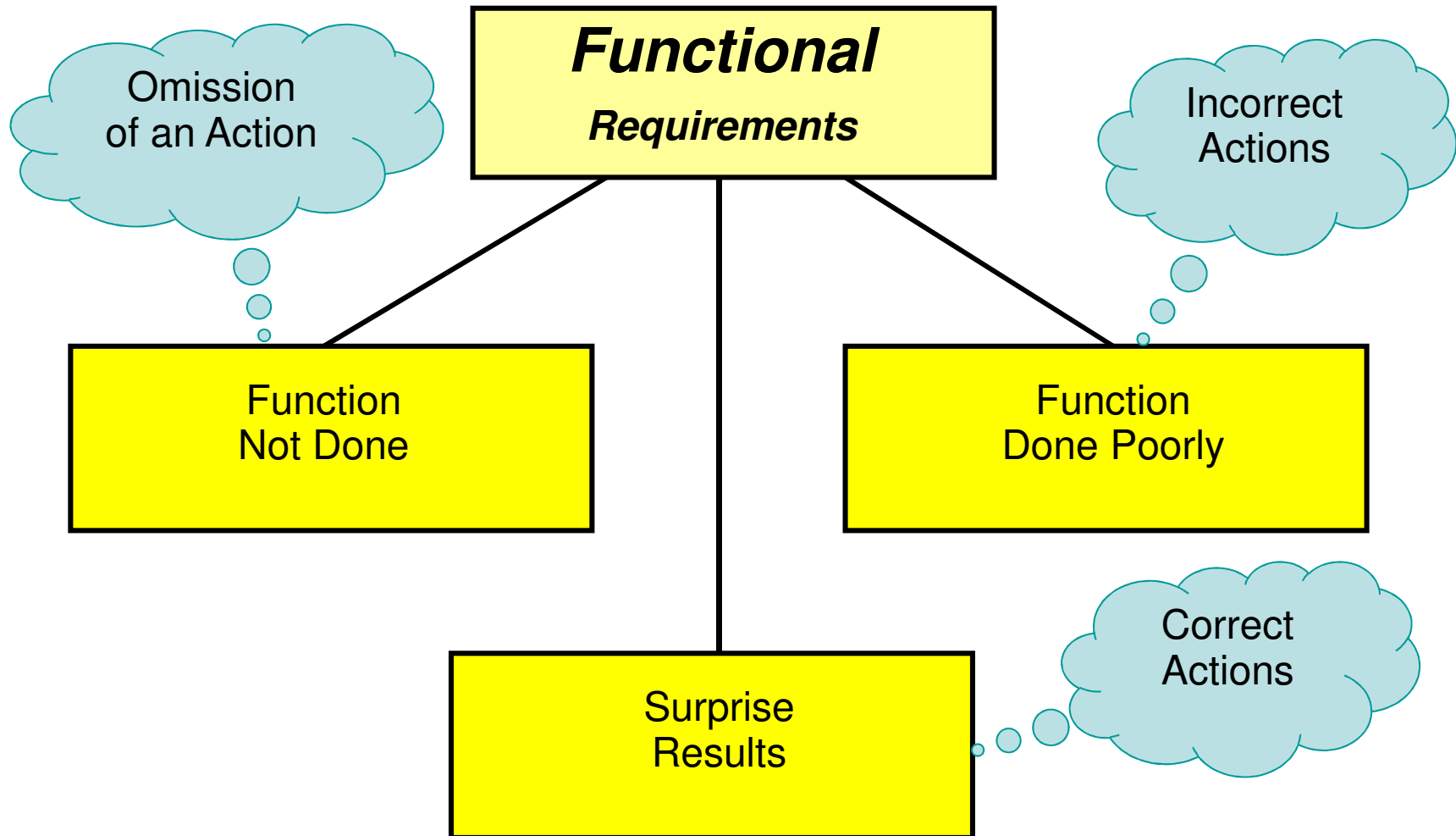

# Example: *Failure Modes*

Color Change System

Spray Paint

Function

Dispense  
Paint  
Properly

Failure Modes

No Paint

Spitting Paint

Stream of Paint

Too Much Paint

Too Little Paint

Void in Fan

# Example: *Failure Modes*

Color Change System

Measure Fluid Flow

Function

Send Accurate  
Feedback Signal

Failure Modes

No Feedback Signal

Intermittent Signal

Signal Too High

Signal Too Low

Feedback Signal with No Flow

Flow Meter Restricts Flow

# Example of Failure Modes

Process Step:

DRILL HOLE THRU

Functional requirements or specifications:

HOLE SIZE

$\phi 12.5 \pm 0.25$

Potential Failure Modes

NO HOLE

HOLE TOO LARGE

HOLE TOO SMALL

HOLE VIOLATES MMC BOUNDARY

HOLE NOT DRILLED THRU

# Example of Failure Modes

Process Step:

DRILL HOLE THRU

Functional requirements or specifications:

LOCATION

$\varnothing 0.5 @ MMC$

Potential Failure Modes

LOCATIONAL ERROR

AXIS OF HOLE  
VIOLATES  
TOLERANCE ZONE

ORIENTATION ERROR

AXIS OF HOLE  
VIOLATES  
TOLERANCE ZONE

# Identify Process and Function – Traditional Format

Process Step Function	Potential Failure Mode	Potential Effects of Failure	S e v	C l a s s	Potential Causes/ Mechanisms of Failure	O C C	Current Process Control (Prevention)	Current Process Control (Detection)	D e t	R. P. N.
Clearance hole for 12 mm bolt - Hole size	No hole									
	Hole too large									
	Hole too small									
	Hole violates MMC boundary									
- Hole Depth	Hole not drilled thru									
- Hole location - No burrs										

# Failure Mode

# Identification Worksheet

Process Step:

Potential Failure Modes

Functional requirements  
or specifications:

# 5. Identify Potential Causes

---

- Potential cause of failure describes how a process failure could occur, in terms of something that can be controlled or corrected.
- Our goal is to describe the direct relationship that exists between the cause and resulting process failure mode.
- Document a unique failure sequence with each potential cause.



# Causes

Causes  
Precede the  
Failure Mode

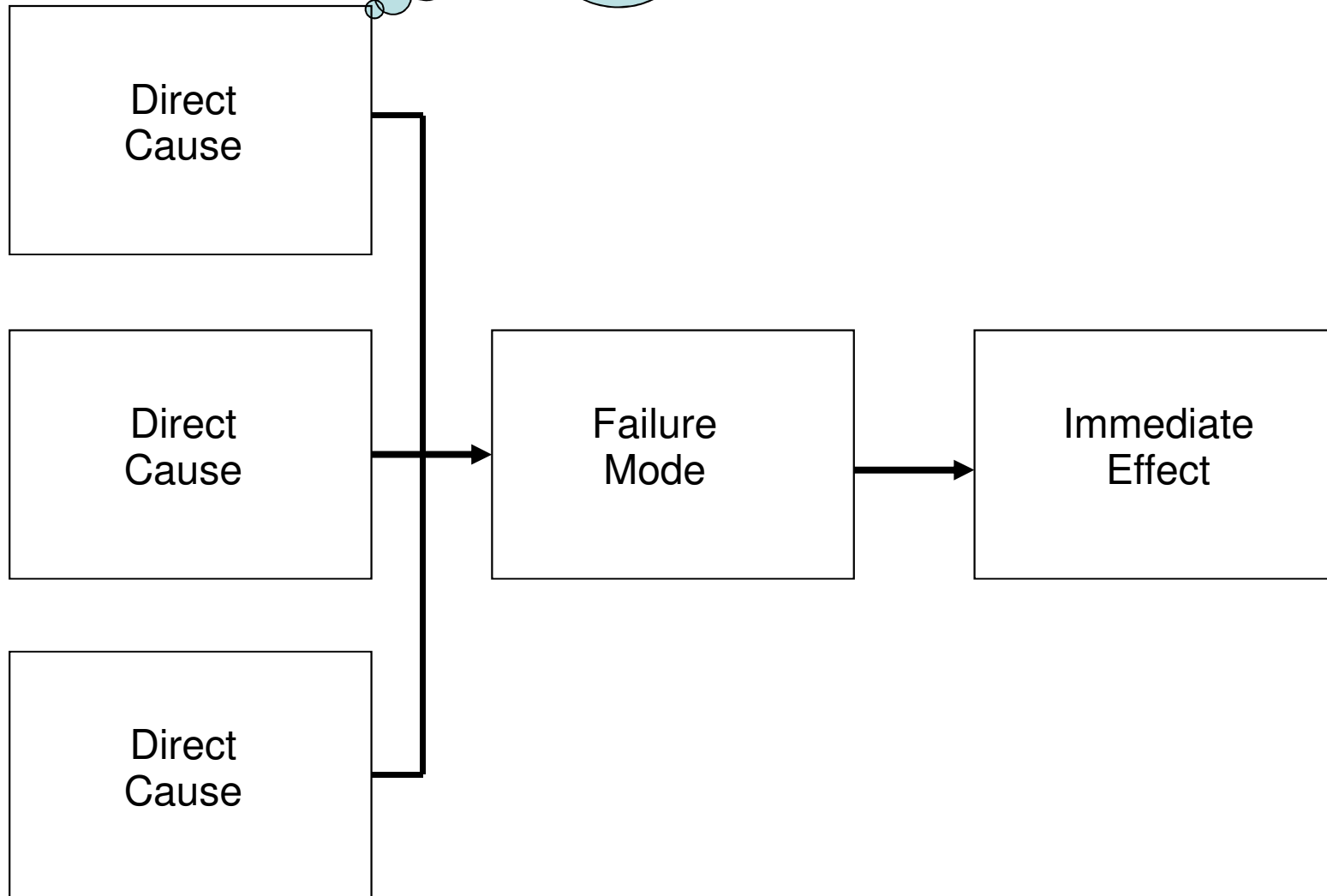

# FMEA Worksheet Form

## FMEA Worksheet

Occ. \_\_\_\_\_ Det. \_\_\_\_\_

Cause 1 <input type="checkbox"/>	←	Control 1 <input type="checkbox"/>	_____
Cause 2 <input type="checkbox"/>	←	Control 2 <input type="checkbox"/>	_____
Cause 3 <input type="checkbox"/>	←	Control 3 <input type="checkbox"/>	_____
Cause 4 <input type="checkbox"/>	←	Control 4 <input type="checkbox"/>	_____
Cause 5 <input type="checkbox"/>	←	Control 5 <input type="checkbox"/>	_____
Cause 6 <input type="checkbox"/>	←	Control 6 <input type="checkbox"/>	_____
Cause 7 <input type="checkbox"/>	←	Control 7 <input type="checkbox"/>	_____

Process Item/  
Functional Requirement: \_\_\_\_\_

Failure Mode

Failure Mode Control

Effect 1 <input type="checkbox"/>	Effect 2 <input type="checkbox"/>	Effect 3 <input type="checkbox"/>	Effect 4 <input type="checkbox"/>
-----------------------------------	-----------------------------------	-----------------------------------	-----------------------------------

Sev. \_\_\_\_\_

# Transfer of Failure Mode to Worksheet

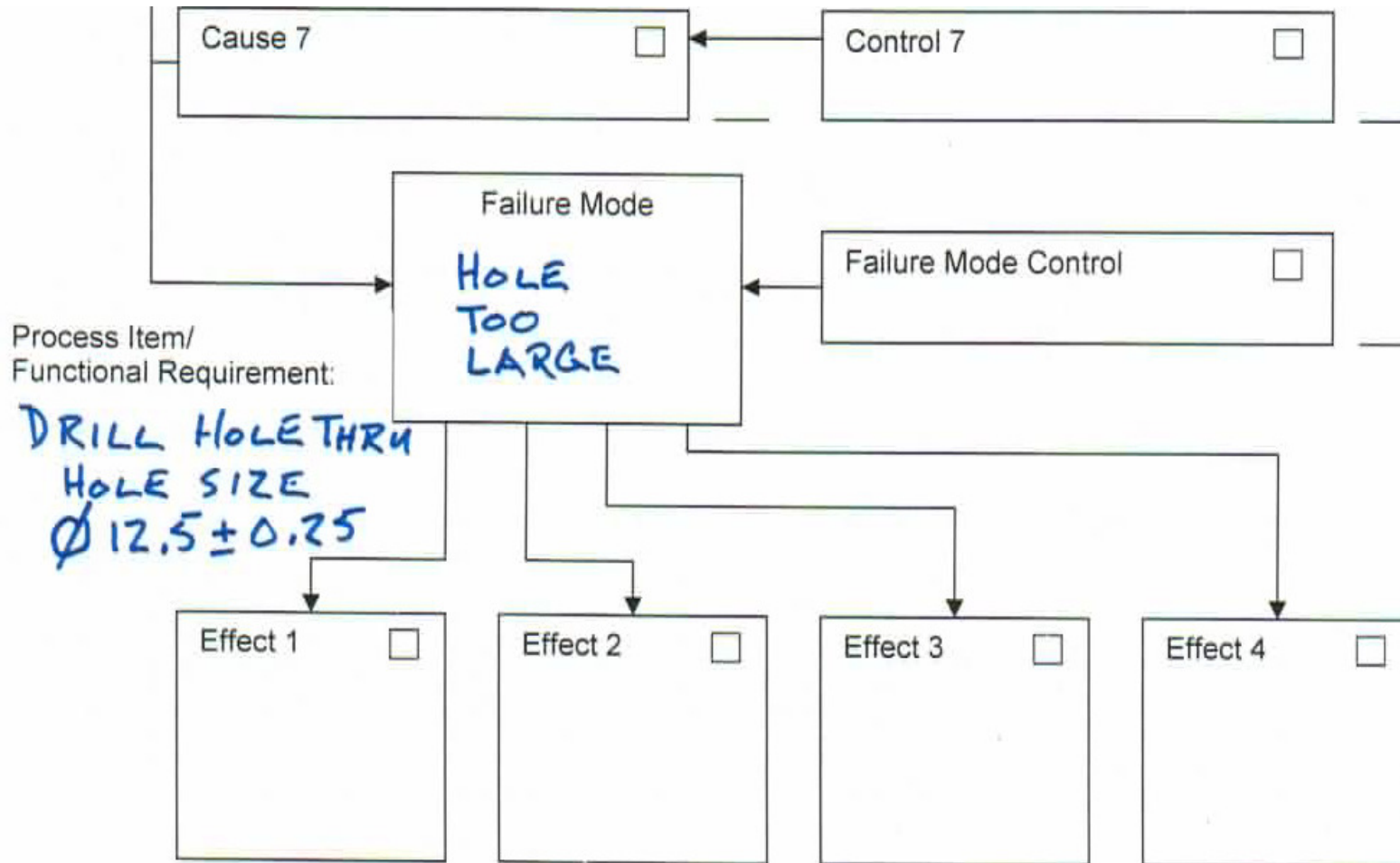

# Example of Causes

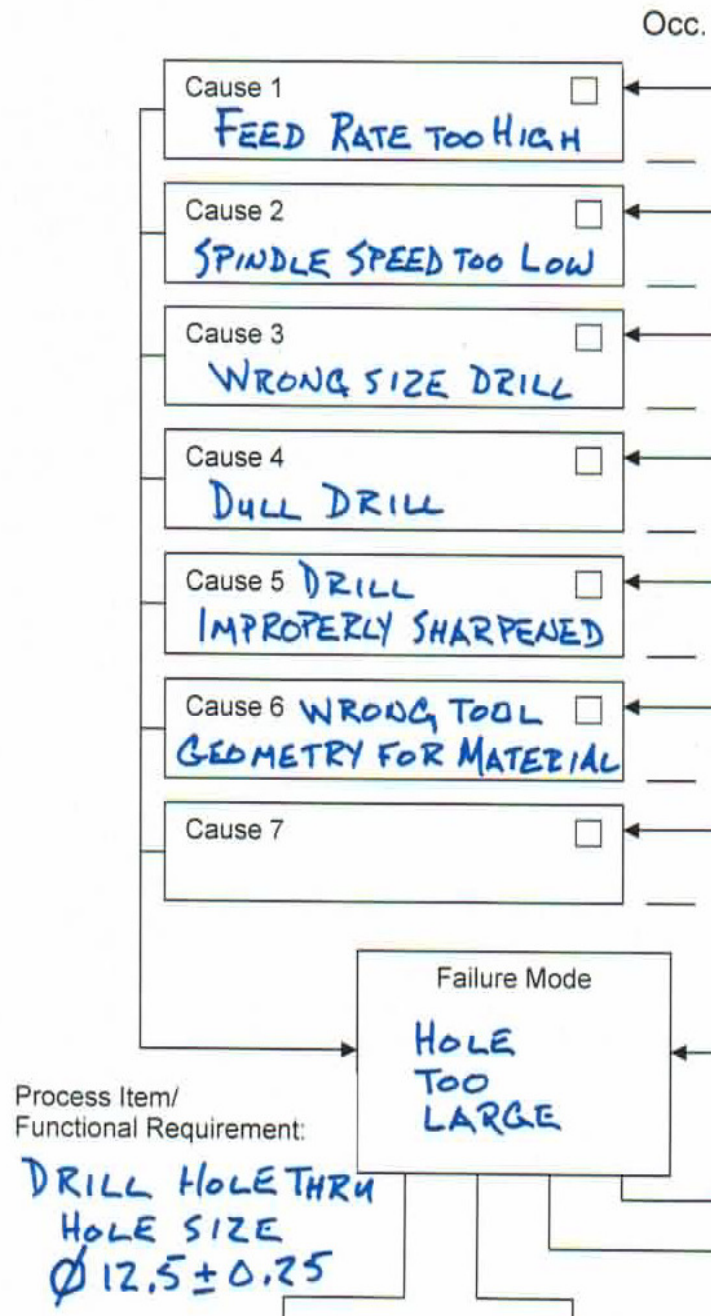

# Example of Causes

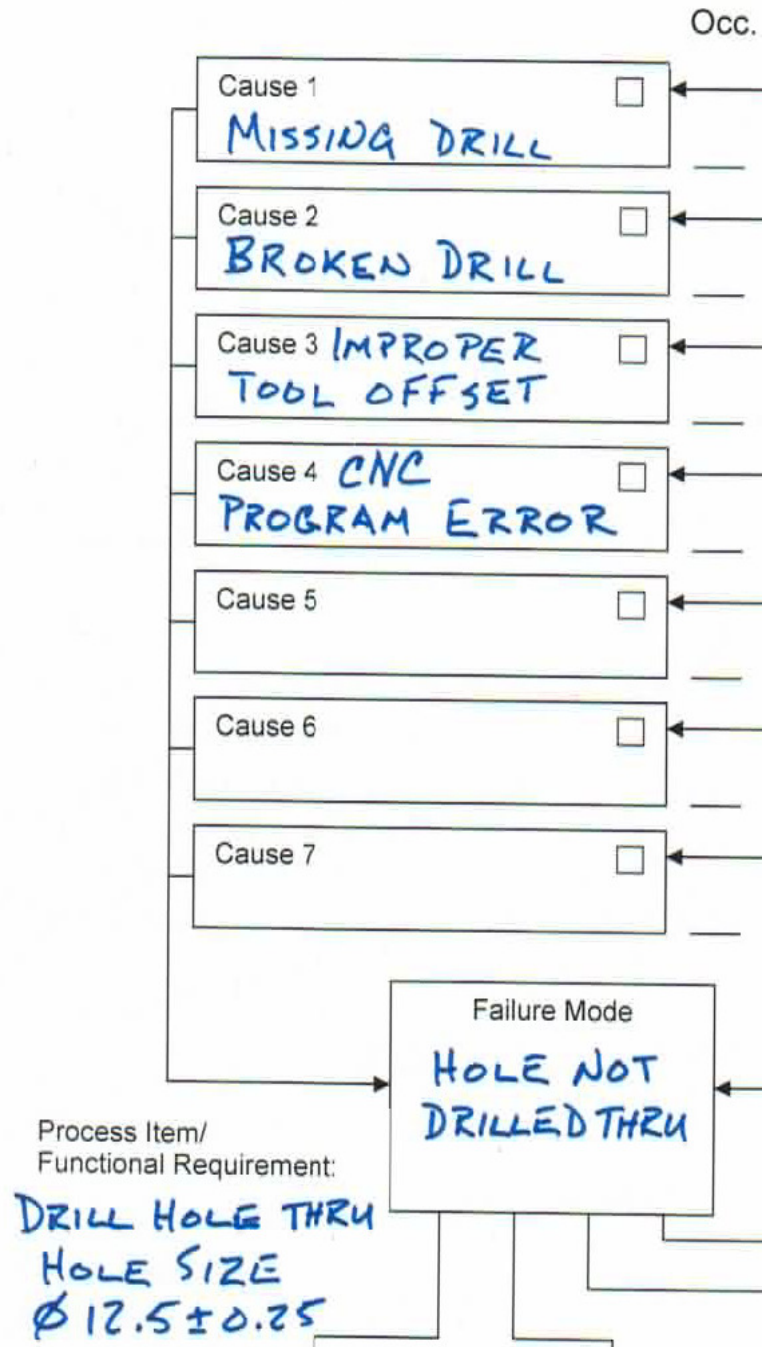

# Identify Causes of Failure – Traditional Format

Process Step Function	Potential Failure Mode	Potential Effects of Failure	S e v	C l a s s	Potential Causes/ Mechanisms of Failure	O C C	Current Process Control (Prevention)	Current Process Control (Detection)	D e t	R. P. N.
Clearance hole for 12 mm bolt - Hole size	Hole too large				Feed rate too high					
					Spindle speed too slow					
					Wrong drill size					
					Drill improperly sharpened					
					Wrong tool geometry for material					
- Hole depth	Hole not drilled thru				Missing drill					

# 6. Identify Potential Effects

---

- Potential effects of a process failure are defined as the result of the failure mode as perceived by the customer.
- The intent is to describe the impact of the failure in terms of what the customer might notice or experience.
- This applies to both internal and external customers.

# Causes and *Effects*

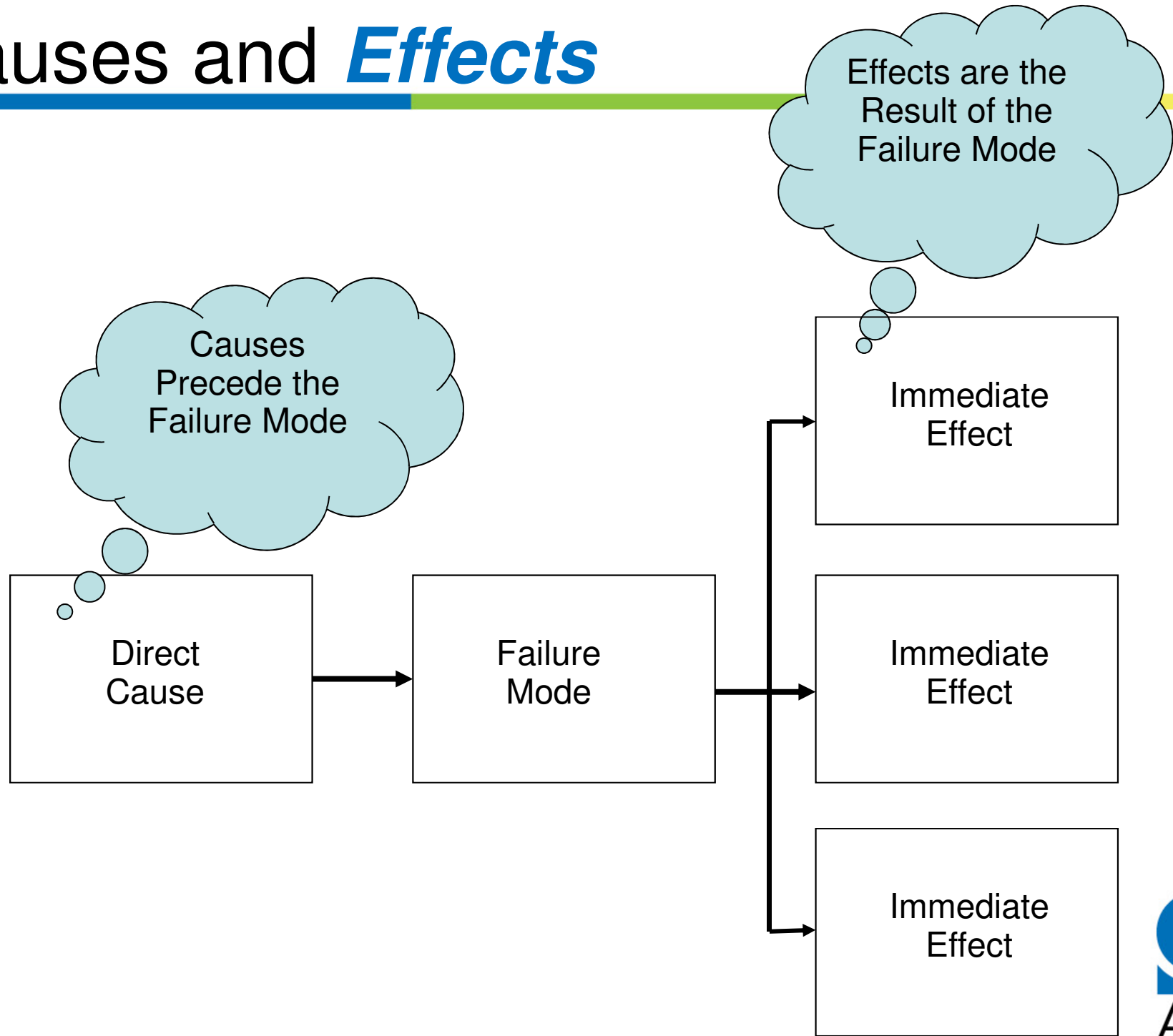



# *Two Focal Points* for Effects

An effect is the immediate consequence of the failure mode.

- What is the *pain* that is felt by the end user?
- What is the *pain* felt by downstream manufacturing or assembly operations?

# Example of Effects

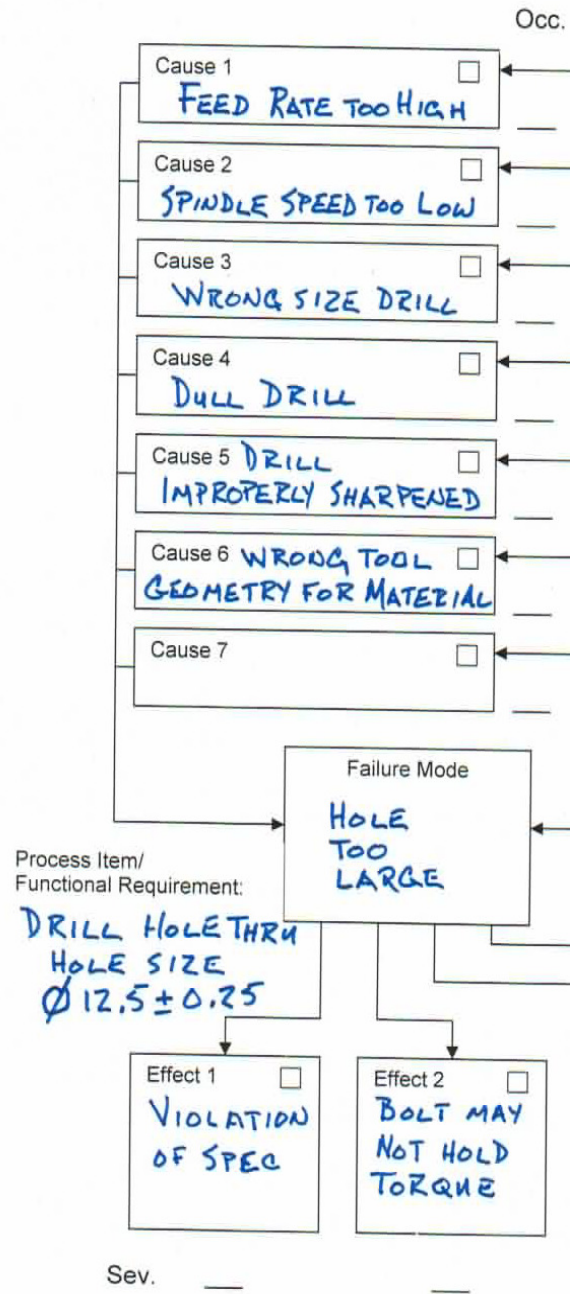

# Example of Effects

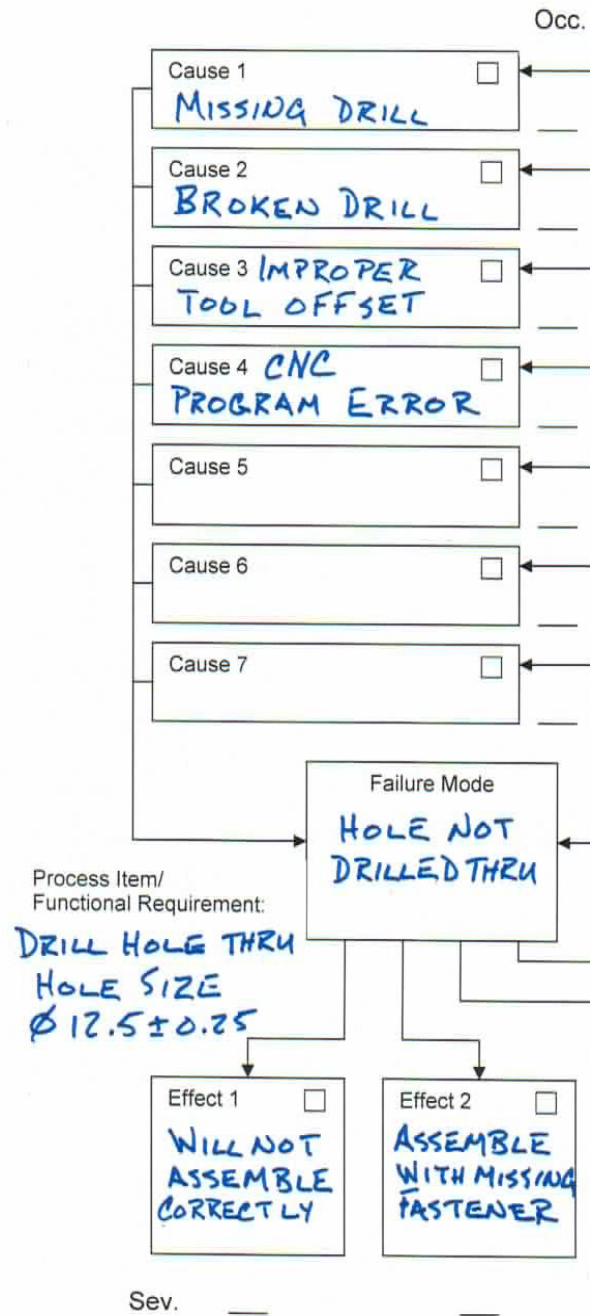

# Identify Effects of Failure – Traditional Format

Process Step Function	Potential Failure Mode	Potential Effects of Failure	S e v	C l a s s	Potential Causes/ Mechanisms of Failure	O c c	Current Process Control (Prevention)	Current Process Control (Detection)	D e t	R. P. N.
Clearance hole for 12 mm bolt - Hole size	Hole too large	Bolt may not hold torque  Violation of specification			Feed rate too high					
					Spindle speed too slow					
					Wrong drill size					
					Drill improperly sharpened					
					Wrong tool geometry for material					
- Hole depth	Hole not drilled thru	Assemble with missing fastener			Missing drill					

# 7. Identify *Current Controls*

- Current Process Controls describe planned activities or devices that can prevent or detect the cause of a failure or a failure mode itself.
- There are two classes of controls:
  - Preventive controls either eliminate the causes of the failure mode or the failure mode itself, or reduce how frequently it occurs.
  - Detective controls recognize a failure mode or a cause of failure so associated countermeasures are put into action.
- Preventive controls are the preferred approach because they are most cost effective.

# Two Types of *Detection*

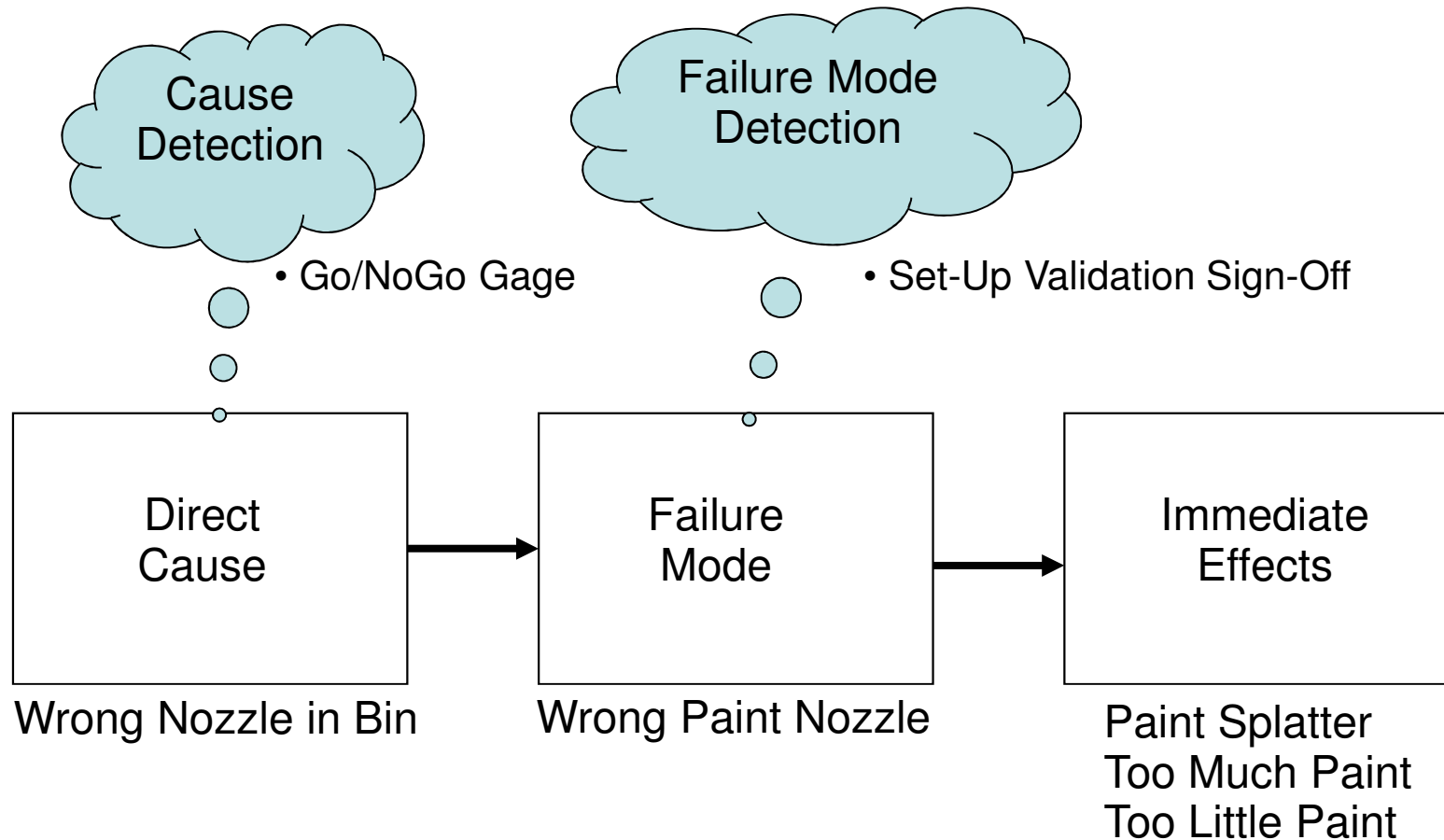

# Example of Process Controls

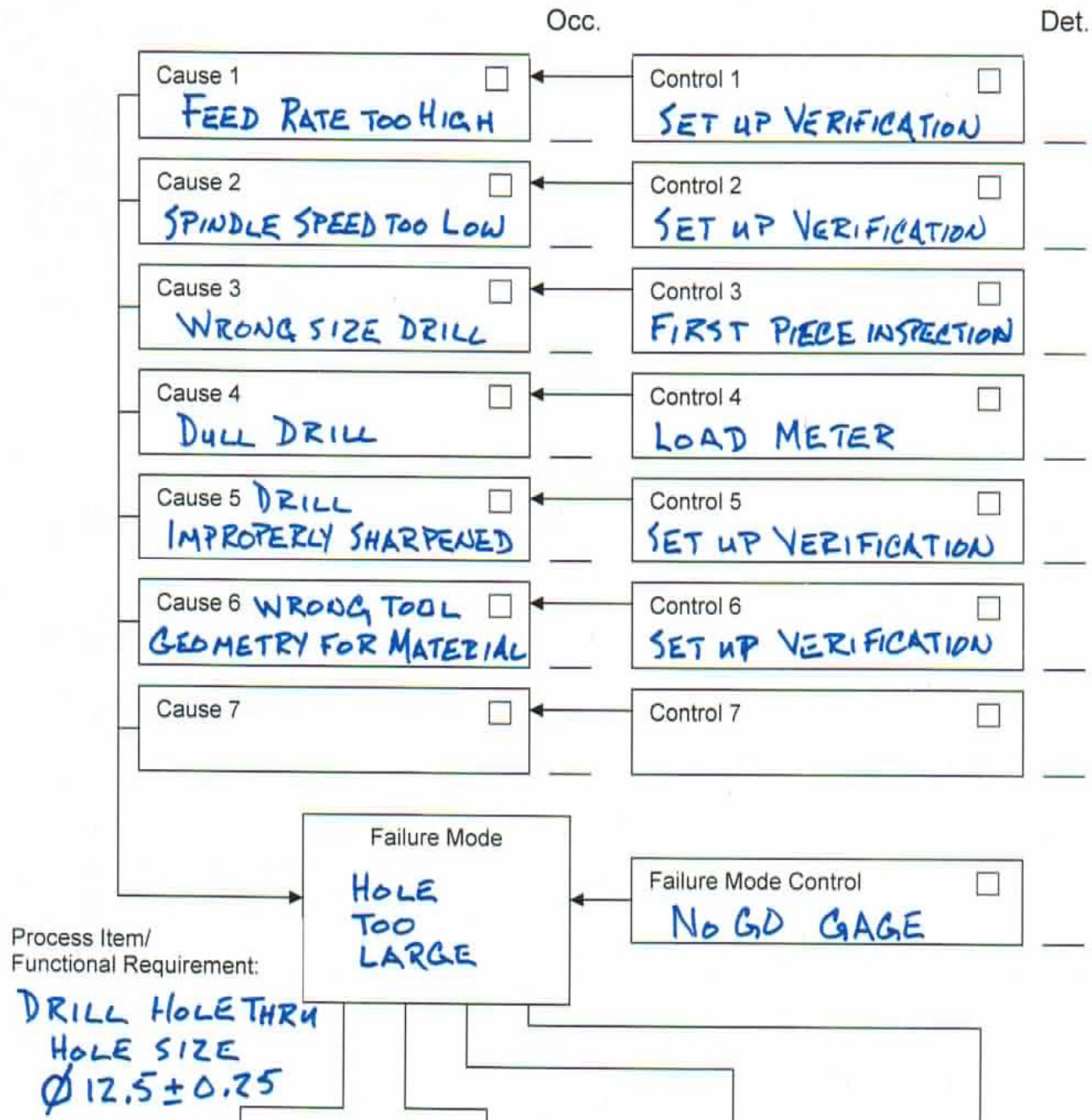

# Example of Process Controls

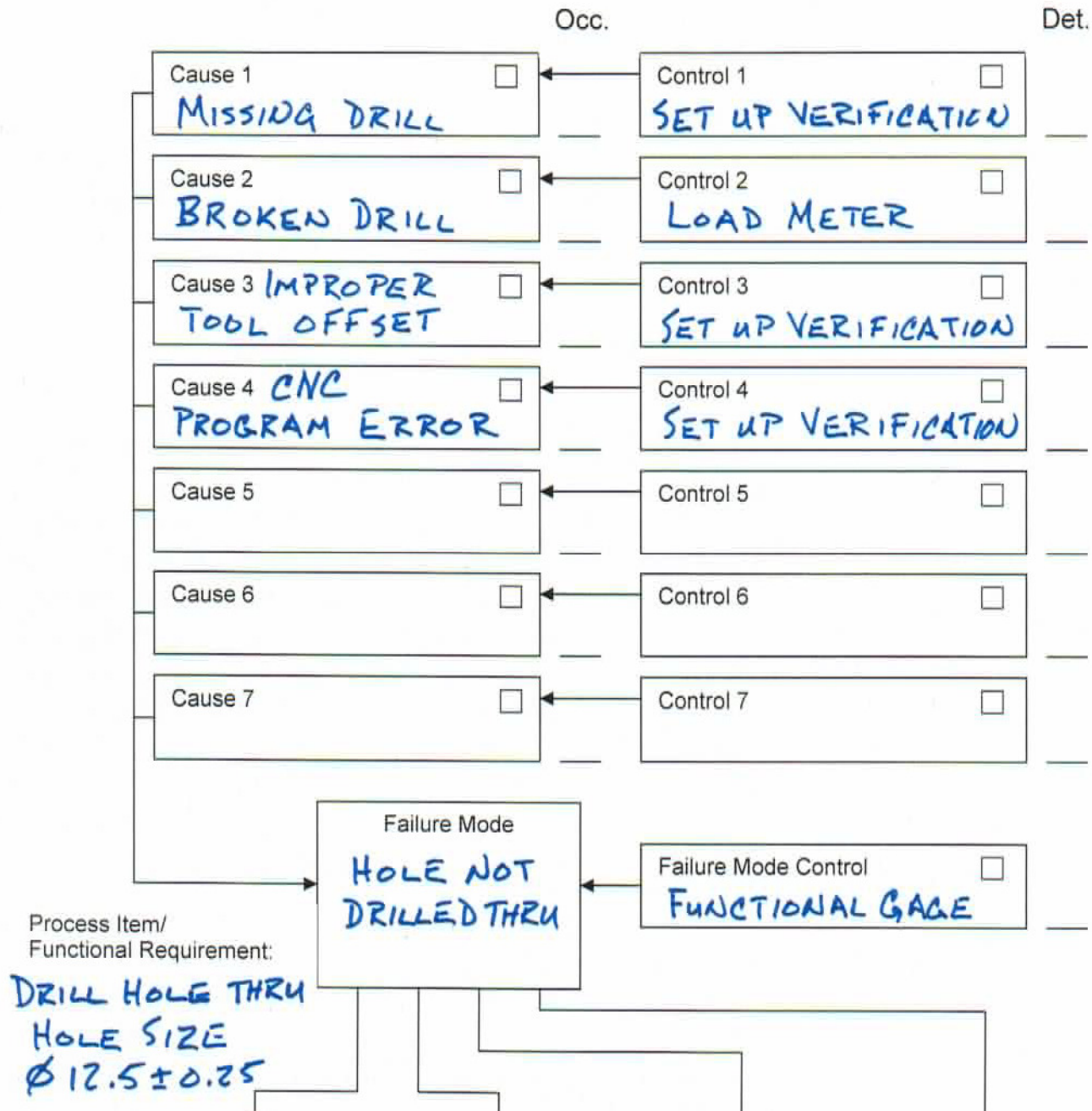



# Identify Current Controls – Traditional Format

Process Step Function	Potential Failure Mode	Potential Effects of Failure	S e v	C l a s s	Potential Causes/ Mechanisms of Failure	O C C	Current Process Control (Prevention)	Current Process Control (Detection)	D e t	R. P. N.
Clearance hole for 12 mm bolt - Hole size	Hole too large	Bolt may not hold torque  Violation of specification			Feed rate too high		DOE Results	Set Up Verification		
					Spindle speed too slow		DOE Results	Set Up Verification		
					Wrong drill size			First Piece Inspection		
					Dull drill bit			Load Meter		
					Drill improperly sharpened			Set Up Verification		
					Wrong tool geometry for material		DOE Results	Set Up verification		

## 8. *Identify* and *Prioritize Risk*

- Risk in a Process FMEA is identified in three ways:
  - Severity – which measures the effect.
  - Occurrence – to assess the frequency of causes.
  - Detection – ability to detect causes or failures.
- It is appropriate to assess these three scores through the understanding of your customer's requirements.

# Severity of Effect

Effect	Severity of Effect on Product (Effect on Customer)	Severity Rank	Effect	Severity of Effect on Process (Effect on Manufacturing or Assembly)
Fails to meet Safety or Regulatory Requirements	Potential failure mode affects safe vehicle operation without warning or involves noncompliance with government regulations.	10	Fails to meet Safety or Regulatory Requirements	May endanger operator (machine or assembly) without warning.
	Potential failure mode affects safe vehicle operation with some warning or noncompliance with government regulations.	9		May endanger operator (machine or assembly) with warning.
Loss or Degrading of Primary Function	Loss of primary function (vehicle inoperable, but does not affect safe vehicle operation).	8	Major Disruption	100% of product may be scrap. Stop production or stop shipment.
	Degradation of primary function (vehicle still operates, but at a reduced level of performance).	7	Significant Disruption	Portion of a production run may be scrapped. Deviation from primary process, decreased line speed, or additional manpower required.
Loss or Degrading of Secondary Function	Loss of secondary function (vehicle still operable, but comfort or convenience functions do not work).	6	Moderate Disruption	100% of a production run may require off-line rework prior to acceptance.
	Degradation of secondary function (vehicle still operates, but comfort or convenience functions perform at reduced levels).	5		Portion of a production run may require off-line rework prior to acceptance.
Annoyance	Appearance item or audible noise (vehicle still operable but not conform, annoys more than 75% of customers).	4		100% of a production run may require rework in-station before it can be processed.
	Appearance item or audible noise (vehicle still operates but does not conform, annoys 50% of customers).	3	Portion of a production run may require rework in-station before it can be processed.	
	Appearance item or audible noise (vehicle still operates but does not conform, annoy less than 25% of customers).	2	Minor Disruption	Slight inconvenience to process, operation, or operator.
No Effect	No discernible effect.	1	No Effect	No discernible effect.

# Frequency of Occurrence

Likelihood of Failure	Occurrence of Causes (Incidents per items or vehicles)	Occurrence Rank
Very High	> 100 per 1000	10
	> 1 per 10	
High	50 per 1000	9
	1 in 20	8
	20 per 1000	
	1 in 50	7
	10 per 1000	
	1 in 100	
Moderate	2 per 1000	6
	1 in 500	5
	0.5 per 1000	
	1 in 2,000	4
	0.1 per 1000	
	1 in 10,000	
Low	0.01 per 1000	3
	1 in 100,000	2
	< 0.001 per 1000	
	1 in 1,000,000	
Very Low	Failure eliminated by preventive control.	1

# Detection by Current Control

Detection Opportunity	Detection by Process Control	Detection Rank	Detection Likelihood
No Detection Capability	No current process control; cannot detect; is not analyzed.	10	Near Impossible
Not Likely to Detect at any Stage	Failure and errors (causes) are not easily to detect (e.g.: random process audits).	9	Very Remote
Problem Detection Post-Process	Post-processing failure mode detection by operator using visual, tactile, or audible means.	8	Remote
Problem Detection at Source	In-station failure mode detection by operator using visual, tactile, or audible means, or by attribute gages.	7	Very Low
Problem Detection Post-Process	Post-processing failure mode detection by operator via variable gages or in-station by operator using attribute gages.	6	Low
Problem Detection at Source	In-station failure mode or error (cause) detection by operator via variable gages or by automated in-station controls that notify the operator. Also gaging on set up; first piece inspection.	5	Moderate
Problem Detection Post-Process	Post-processing failure mode detection by automated controls that detect nonconforming parts and prevent further processing.	4	Moderately High
Problem Detection at Source	In-station failure mode detection by automated controls that detect nonconforming parts and prevent further processing on them.	3	High
Error Detection with Problem Prevention	In-station error (cause) detection by automated controls that detect an error and prevent bad parts from being made.	2	Very High
Detection does not Apply; Error Prevention	Error (cause) prevention via fixture design, machine design, or part design. Bad parts can not be made; product and process error-proofed.	1	Near Certain

# Assess Severity, Occurrence, Detection

Process Step Function	Potential Failure Mode	Potential Effects of Failure	S e v	C l a s s	Potential Causes/ Mechanisms of Failure	O c c	Current Process Control (Prevention)	Current Process Control (Detection)	D e t	R. P. N.

**Severity** evaluates the impact of the effect.

**Occurrence** rates how often a specific cause is likely to result in the failure mode being analyzed.

**Detection** ranks our ability to detect either a cause or a resulting failure mode. Use best detection available.

# Example of Severity, Occurrence, Detection

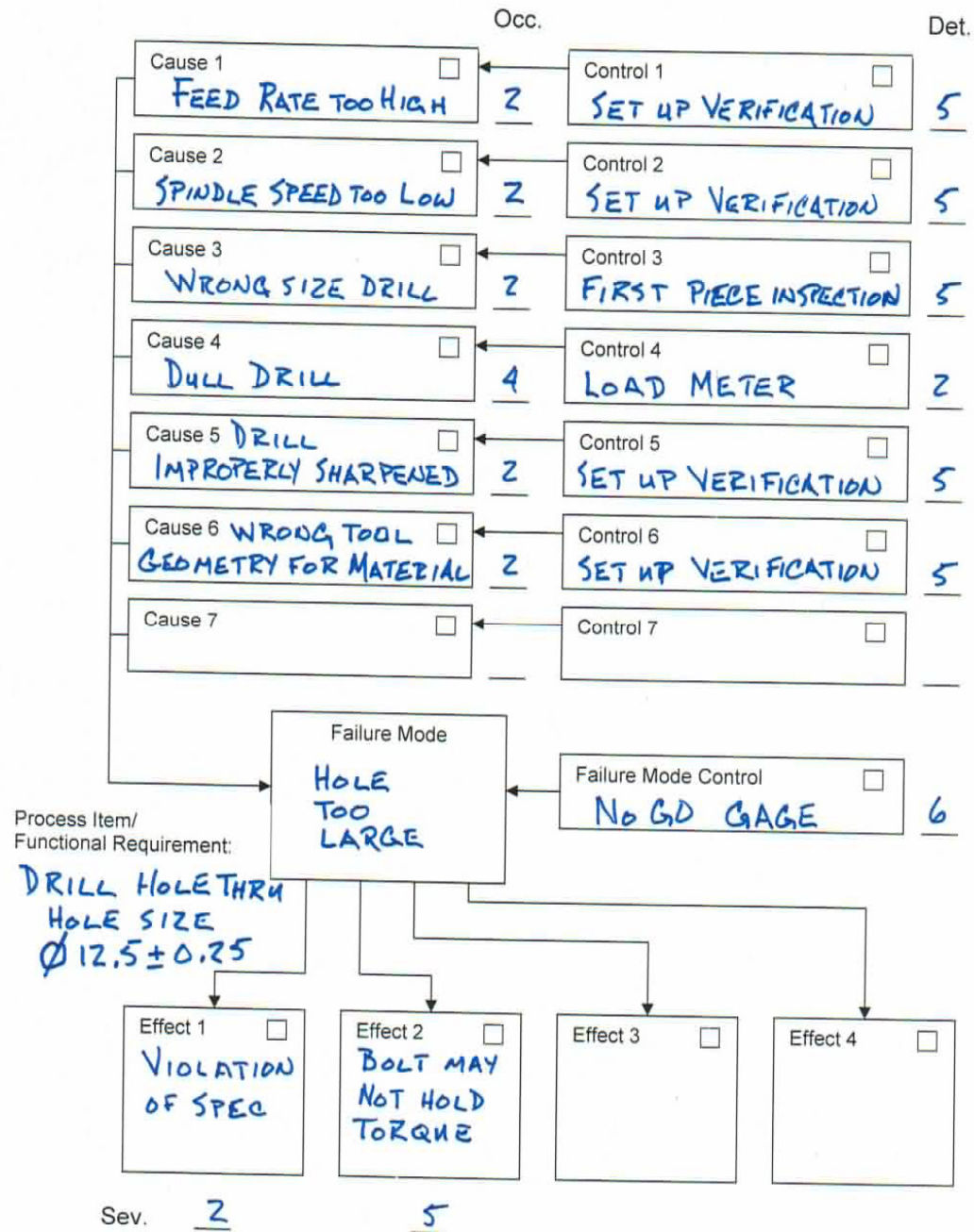

# Example of Severity, Occurrence, Detection

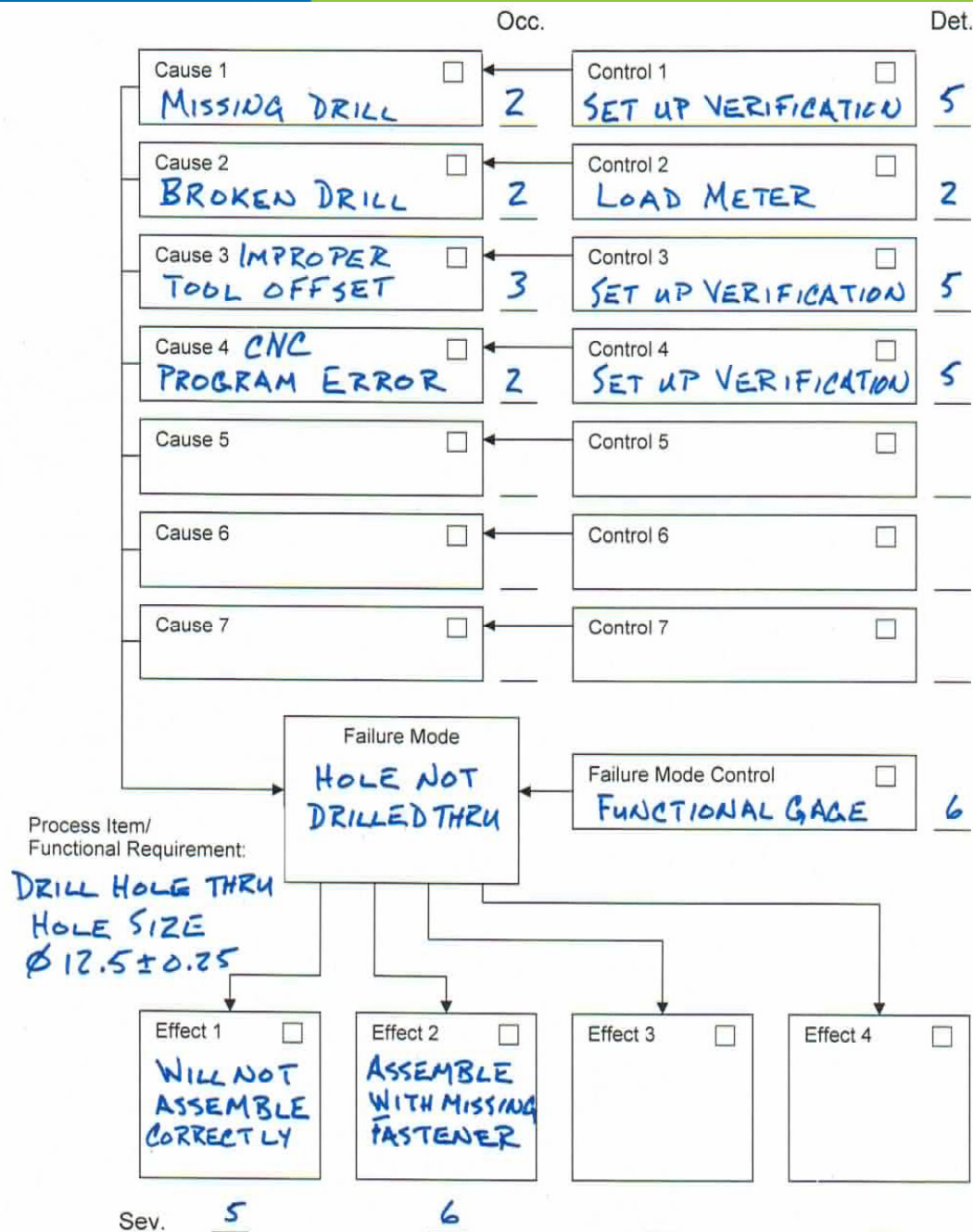



# *Prioritization* of Risk

Several strategies exist for the mitigation of risk, for example:

1. High Risk Priority Numbers
2. High Severity Risks (regardless of RPN)
3. High Design Risks (Severity x Occurrence)
4. Other Alternatives (S,O,D) and (S,D)

**NOTE:** *“The use of an RPN threshold is NOT a recommended practice for the need for action.”*

# Identify Current Controls – Traditional Format

Process Step Function	Potential Failure Mode	Potential Effects of Failure	Sev	Class	Potential Causes/ Mechanisms of Failure	OCC	Current Process Control (Prevention)	Current Process Control (Detection)	Det	R.P.N.
Clearance hole for 12 mm bolt - Hole size	Hole too large	Bolt may not hold torque  Violation of specification	5		Feed rate too high	2	DOE Results	Set Up Verification	5	50
					Spindle speed too slow	2	DOE Results	Set Up Verification	5	50
					Wrong drill size	2		First Piece Inspection	5	50
					Dull drill bit	4		Load Meter	2	40
					Drill improperly sharpened	2		Set Up Verification	5	50
					Wrong tool geometry for material	2	DOE Results	Set Up verification	5	50

# 9. Recommend Actions

---

- The intent with recommended actions is to reduce risk.
- Recommended actions will be focused to:
  - Reduce Severity
  - Reduce Frequency of Occurrence
  - Improve Detection

# Managing *Recommended Actions*

- Transfer FMEA action items onto the mechanism used to track and ensure closure of open issues on the project.
- Decisions to take different actions or not to act must be approved.
- Review status of FMEA action items on a regular basis.

# Recommended Actions

Recommended Actions	Responsibility & Target Completion Date	Action Results				
		Actions Taken	S e v	O c c	D e t	R. P. N.

# 10. Verify Results

---

- Whenever you change a process one of two things happen:
  - Things Get Better
  - Things Get Worse
- Verify actual performance following the implementation of the recommended actions.

---

# Summary and Closure



# *Key Points* to Remember

Upon successful completion of this course, you should know:

1. Potential FMEA Reference Manual is the authoritative reference.
2. Severity scores of 9 or 10 must be used for safety related risks.
3. Occurrence ranks how often each cause is likely to result in failure.
4. It is appropriate to focus on high severity items first.
5. Credit for preventive actions shows up in the frequency of occurrence.
6. Risk Priority Numbers provides a rank order to risks and action items.
7. An effective approach is to continually focus on the top five concerns.
8. Process FMEA should result in tangible improvement to process performance.







Automotive  
Division  
The Global Voice of Quality™

# Questions and Answers

Please type your  
questions in the panel  
box



The Global Voice of Quality™



Automotive  
Division  
The Global Voice of Quality™



# Thank You For Attending

Please visit our website

[www.asq-auto.org](http://www.asq-auto.org) for future webinar dates  
and topics.

